

Federal Communications Commission Statement(Class A)



NOTE- This equipment has been tested and found to comply with the limits for a Class A digital device, pursuant to Part 15 of the FCC Rules. These limits are designed to provide reasonable protection against harmful interference in a residential installation. This equipment generates uses and can radiate radio frequency energy and, if not installed and used in accordance with the instructions, may cause harmful interference to radio communications. However, there is no guarantee that interference will not occur in a particular installation. If this equipment does cause harmful interference to radio or television reception, which can be determined by tuning the equipment off and on, the user is encouraged to try to correct the interference by one or more of the following measures:

- Reorient or relocate the receiving antenna.
- Increase the separation between the equipment and receiver.
- Connect the equipment into an outlet on a circuit different from that to which the receiver is connected.
- Consult the dealer or an experienced radio/television technician for help.

Class A ITE:

Class A ITE is a category of all other ITE which satisfies the class A ITE limits but not the class B ITE limits. Such equipment should not be restricted in its sale but the following warning shall be included in the instructions for use:

Warning - This is a class A product. In a domestic environment this product may cause radio interference in which case the user may be required to take adequate measures.

CE Class A (EMC)



This product is herewith confirmed to comply with the requirements set out in the Council Directives on the Approximation of the laws of the Member States relating to Electromagnetic Compatibility Directive 2004/108/EEC.

Warning - This is a Class A product. In a domestic environment this product may cause radio interference in which case the user may be required to take adequate measures to correct this interference.

DISCLAIMER

No warranty or representation, either expressed or implied, is made with respect to the contents of this documentation, its quality, performance, merchantability, or fitness for a particular purpose. Information presented in this documentation has been carefully checked for reliability; however, no responsibility is assumed for inaccuracies. The information contained in this documentation is subject to change without notice.

In no event will AVerMedia be liable for direct, indirect, special, incidental, or consequential damages arising out of the use or inability to use this product or documentation, even if advised of the possibility of such damages.

TRADEMARKS

AVerVision is registered trademarks of AVerMedia Information, Inc. IBM PC is a registered trademark of International Business Machines Corporation. Macintosh is a registered trademark of Apple Computer, Inc. Microsoft is a registered trademark and Windows is a trademark of Microsoft Corporation. All other products or corporate names mentioned in this documentation are for identification and explanation purposes only, and may be trademarks or registered trademarks of their respective owners.

COPYRIGHT

© 2009 by AVerMedia Information, Inc. All rights reserved. No part of this publication may be reproduced, transmitted, transcribed, stored in a retrieval system, or translated into any language in any form by any means without the written permission of AVerMedia INFORMATION, Inc.



THE MARK OF CROSSED-OUT WHEELED BIN INDICATES THAT THIS PRODUCT MUST NOT BE DISPOSED OF WITH YOUR OTHER HOUSEHOLD WASTE. INSTEAD, YOU NEED TO DISPOSE OF THE WASTE EQUIPMENT BY HANDING IT OVER TO A DESIGNATED COLLECTION POINT FOR THE RECYCLING OF WASTE ELECTRICAL AND ELECTRONIC EQUIPMENT. FOR MORE INFORMATION ABOUT WHERE TO DROP OFF YOUR WASTE EQUIPMENT FOR RECYCLING, PLEASE CONTACT YOUR HOUSEHOLD WASTE DISPOSAL SERVICE OR THE SHOP WHERE YOU PURCHASED THE PRODUCT.

Remote Control Battery Safety Information

- Store batteries in any cool & dry place.
- Do not dispose used batteries in domestic waste. Dispose batteries at special collection points or return to stores if applies.
- Remove the batteries if they are not in use for long period of time. Battery leakage and corrosion can damage the remote control, dispose batteries safely.
- Do not mix and use old and new batteries.
- Do not mix and use different types of batteries: alkaline, standard (carbon-zinc) or rechargeable (nickel-cadmium).
- Do not dispose batteries in a fire.
- Do not attempt to short circuit the battery terminals.

Class 2 Laser Product



LASER RADIATION
DO NOT STARE INTO BEAM
CLASS 2 LASER PRODUCT

Table of Contents

Package Contents	1
Optional Accessories	1
Get Familiar with the AVerVision355AF	2
Right Panel.....	2
Rear Panel	3
Left Panel	3
Control Panel.....	4
Remote Control	5
Making the Connections	7
Set the TV-RGB Switch Setting	7
Connect to a Monitor or LCD/DLP Projector.....	7
Connect to a Monitor or LCD/DLP Projector with DVI-I interface	8
Connect to a TV	8
Connecting the Power	9
Connect to a Computer	9
Connect to a Computer via USB	10
Connect an External Microphone	10
Connect an Amplified Speaker	11
Connect to a Microscope.....	11
Setting Up AVerVision355AF	12
Camera Head	12
Mechanical Arm.....	12
LED Light Switch	13
Infrared Sensor.....	13
Anti-glare Sheet.....	13
External Memory Storage.....	14
Insert an SD Card	14
Insert a USB Flash Drive	14
OSD MENU	15
Select Menu and Settings.....	16
Basic	16
Brightness.....	16
Contrast	16
Auto Image	16
MODE	17
Focus.....	17
Effect.....	17
Default	17
Advanced	18
Exposure	18
White Balance.....	18
Flicker	18
Night View.....	19

Presentation	19
AVerBox On/Off	19
AVerBox Shade	19
AVerBox Resize	20
AVerVisor	20
AVerVisor Shade	20
PIP	20
Split Screen	21
Timer	21
Timer Set	21
Setting	21
Capture Resolution	21
Capture Quality	22
Capture Type	22
Capture Interval	22
Recording Format	22
Recording Quality	22
Current Storage	23
Format Storage	23
System	23
Language	23
Output Resolution	23
USB State	24
Backup	24
Profile Save	24
Profile Recall	24
Information	25
Playback	25
Slide Show	25
Slide Show Interval	25
Slide Show Effect	25
Current Storage	26
Delete All	26
Transfer Captured Images/Videos to a computer	26
Technical Specifications	27
Image	27
Optics	27
Power	27
Lighting	27
Input/Output	27
Dimension	28
External Storage	28
RS-232 Diagram Connection	28
RS-232 Cable Specifications	28
RS-232 Transmission Specifications	29
RS-232 Communication Format	29
RS-232 Command Table	29

RS-232 Function Table.....	30
Troubleshooting.....	36
Limited Warranty.....	37

Package Contents

Make sure the following items are included in the package.

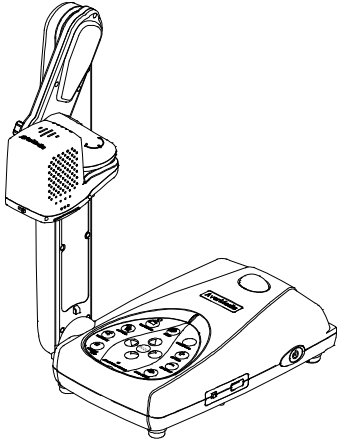

AVerMedia® AVerVision355AF



RS-232/CVBS Cable

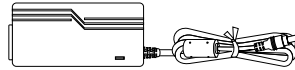

Power Adapter

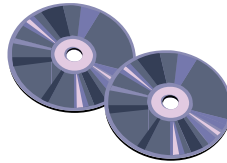

Software & Manual CD

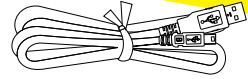

USB Cable

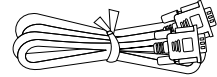

RGB Cable

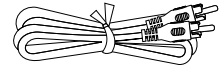

RCA Cable

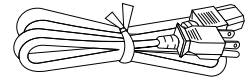

Power Cord

* The power cord will vary depending on the standard power outlet of the country where it is sold.



Carrying Bag



Remote Control
(batteries included)

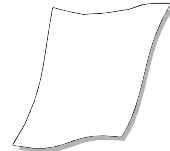

Anti-glare Sheet

Optional Accessories

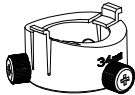

34mm Microscope Adapter



28mm Microscope Adapter

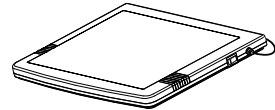

Light Box

Get Familiar with the AVerVision355AF

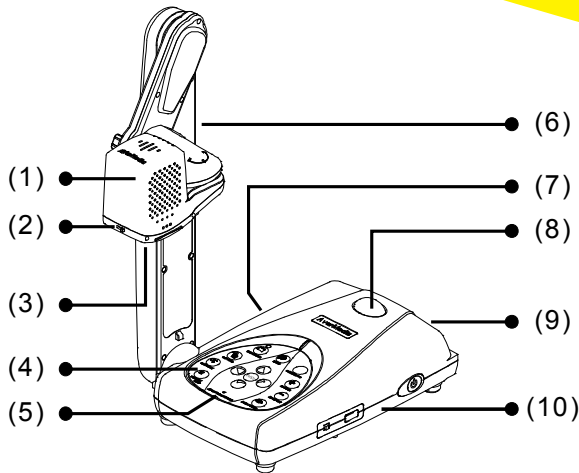

(fig. 1.1)

Name	Function
(1) Camera head	Contain the camera sensor.
(2) LED light switch	Turn on & off among 3 different light settings.
(3) Camera lens	Focus the image in the camera.
(4) Control panel	Easy access to various functions.
(5) Built-in MIC	Record audio when recording video clip. The recorded sound will be in monophonic.
(6) Arm	Extendable for viewing coverage.
(7) Left panel	Connections for microphone, speaker, and computer, SD card, and TV-RGB display output switch.
(8) IR sensor	Receive remote control commands.
(9) Rear panel	Connections for power and external display device.
(10) Right panel	On off switch for USB flash drive port.

Right Panel

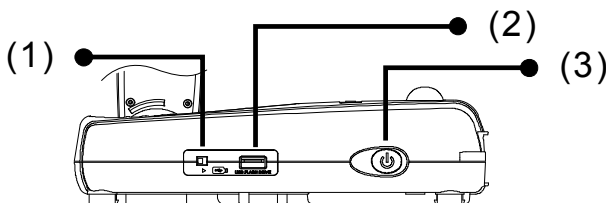

(fig. 1.2)

Name	Function
(1) USB Flash Drive switch	Switch to right (▶) for audio video recording directly to a USB flash drive and left (◀) when connecting AVerVision355AF to a computer using a USB cable.

Name	Function
(2) USB Flash Drive port	Insert a USB flash drive for audio video recording.
(3) Power button	Turn the unit on/standby mode.

Rear Panel

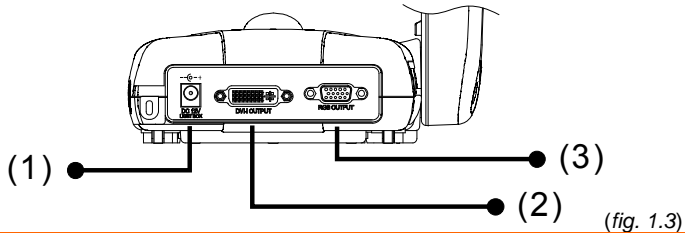

Name	Function
(1) DC12V / LIGHTBOX port	Connect the power adapter into this port.
(2) DVI-I OUTPUT port	Connect the AVerVision355AF to any display device with DVI cable. If the display device does not support DVI-I, you can only view in Camera and Playback mode.
(3) RGB OUTPUT port	Connect the AVerVision355AF to any display device with RGB cable

Left Panel

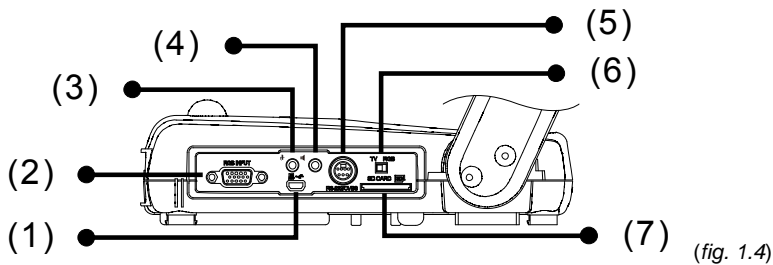

Name	Function
(1) Mini USB port	Connect to a USB port of a computer with a USB cable and use AVerVision355AF as a USB Camera or transfer the captured images/videos either from the memory source to computer.
(2) RGB INPUT port	Input the signal from a computer or other sources and pass it through to the RGB OUTPUT port only. Connect this port to the RGB/VGA output port of a computer.
(3) MIC port	Connect a 3.5mm plug microphone. The built-in mic will be disabled when an external MIC is connected to this port.
(4) Speaker port	Connect to an amplified speaker to playback recorded audio & video clip.
(5) RS-232/CVBS port	Connect the supplied RS-232/CVBS cable into this port. The RCA jack outputs the video signal from the camera to a TV or video equipment. The RS-232 jack is used to connect to computer serial port or to any control panel or for centralized control if desire.

Name	Function
(6) TV-RGB switch	TV switch to output display video from RS232/CVBS (via RCA connection), and RGB to RGB and DVI-I OUTPUT ports.
(7) SD card slot	Insert the SD card with the label facing up.

Control Panel

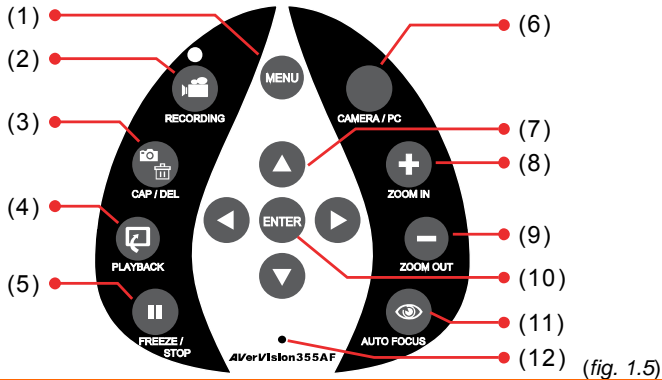

Name	Function
(1) MENU	Open and exit the OSD menu.
(2) RECORDING	Start/Stop audio & video recording. Audio and video recording can be saved on a SD card or an USB Flash drive only. See External Memory Storage .
(3) CAP/DEL	<ul style="list-style-type: none"> - Capture picture in Camera mode. In continuous capture mode, press this button again to stop. - Delete the selected picture/video in Playback mode.
(4) PLAYBACK	View & playback captured still images and audio video files.
(5) FREEZE / STOP	<ul style="list-style-type: none"> - Pause or resume image display in Camera mode. - Stop audio & video playback in Playback mode.
(6) CAMERA / PC	Switch between Camera and Computer.
(7) ▲, ▼, ◀, & ▶	<ul style="list-style-type: none"> - Pan any zoom-in image (above 10x zoom level) in both live and playback mode. - Select options in OSD menu. - Use ▲ & ▼ to increase and decrease the video playback volume. - Use ◀ & ▶ to play the video backward and forward. - Move the AVerBox frame and AVerVisor screen cover.
(8) ZOOM IN	Increase the image magnification in camera and picture playback mode.
(9) ZOOM OUT	Decrease the image magnification in camera and picture playback mode.
(10) ENTER	<ul style="list-style-type: none"> - Make a selection in Playback mode and OSD menu. - Start/Pause video playback.
(11) AUTO FOCUS	Adjust the focus automatically.
(12) Built-in MIC	Record audio automatically when recording video clip

Remote Control

The remote control requires two (2) “AAA” size batteries (supplied), make sure batteries are installed properly before use. You can access all the features of AVerVision355AF with the remote.

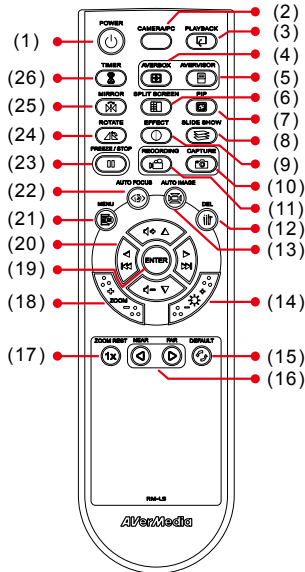

(fig. 1.6)

Name	Function
(1) POWER	Turn the unit on/standby.
(2) CAMERA / PC	Switch between Camera and computer mode. - Camera mode displays the video signal from the built-in camera. - PC mode displays the video signal from the RGB INPUT port of AVERVISION355AF.
(3) PLAYBACK	View the captured picture/video from the memory in 16-thumbnail images.
(4) AVERBOX	Overlay a box frame on the presentation screen, you can move it around and adjust the box size
(5) AVERVISOR	Cover part of the presentation screen and allow presenter to reveal the material as desire.
(6) SPLIT SCREEN	Divide the screen into two. One side displays the live image from the built-in camera and the other side displays 8-thumbnail size picture/video from the memory.
(7) PIP	Show a thumbnail size captured picture/video from the memory at the corner of the screen in Camera mode.
(8) SLIDE SHOW	Start/Stop automatically showing the captured picture/video one-by-one.
(9) EFFECT	Convert and display the image in BW, Negative or Color in Camera and Playback mode only.
(10) CAPTURE	Capture still image in Camera mode. In continuous capture mode, press this button again to stop.
(11) RECORDING	Start/Stop audio & video recording. Video recording can only be saved either in a SD memory card or a USB flash drive.
(12) DEL	Delete the selected picture/video in Playback mode.
(13) AUTO IMAGE	Automatically adjust and set the white balance and exposure setting.
(14) BRIGHTNESS +/-	Adjust the brightness.

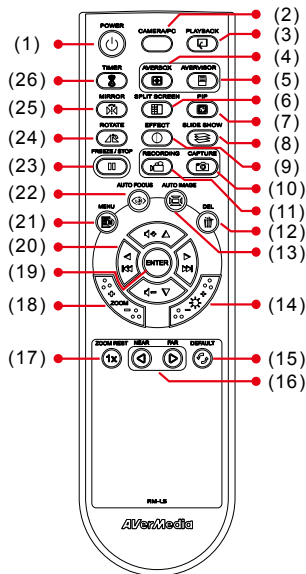

(fig. 1.6)





Name	Function
(15) DEFAULT	Reset at factory default setting.
(16) NEAR / FAR	Adjust the focus manually.
(17) ZOOM RESET	Reset zoom level to 100%.
(18) ZOOM +/-	Increase/decrease the image magnification in camera and picture playback mode.
(19) ENTER	<ul style="list-style-type: none"> - Make a selection in Playback mode and OSD menu. - Start/Pause video playback.
(20) ▲, ▼, ◀, & ▶	<ul style="list-style-type: none"> - Pan the image when image is above 10X zoom in live mode or in playback captured image mode. - Move the selection in Playback mode and in OSD menu. - Use ▲ & ▼ to increase and decrease the video playback volume. - Use ◀ & ▶ to play the video backward and forward. - Move the AVerBox frame and AVerVisor screen cover.
(21) MENU	Open and exit the OSD menu.
(22) AUTO FOCUS	Adjust the focus automatically.
(23) FREEZE / STOP	<ul style="list-style-type: none"> - Freeze live images. - Stop video playback.
(24) ROTATE	Rotate the image by 90° in Camera mode and Playback mode.
(25) MIRROR	Flip the image in Camera mode.
(26) TIMER	Start/Pause timer countdown.

Making the Connections

Before making the connection, make sure the power of all devices are **turned off**. If you are not sure on where to connect, simply follow the illustrated connections below **and also** refer to the user manual of the device you are connecting the AVerVision335AF with.

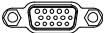
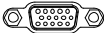
Set the TV-RGB Switch Setting

The TV-RGB switch determines the display output selection. Switch it to RGB (right) to output signal using RGB/DVI-I connection and TV (left) to output signal using RCA connection. (see fig. 1.4 # 6)

Switch	AVerVision Port	To	Display Device Port
RGB	 RGB OUTPUT	To	 RGB INPUT
	 DVI-I OUTPUT		 DVI-I INPUT
TV	 RS232/CVBS (use RS-232/CVBS cable)		 VIDEO IN

Connect to a Monitor or LCD/DLP Projector

Locate the RGB (VGA) input port of the graphics display device and connect it to RGB OUTPUT port of AVERVISION355AF.



Make sure the TV/RGB switch is set to RGB.

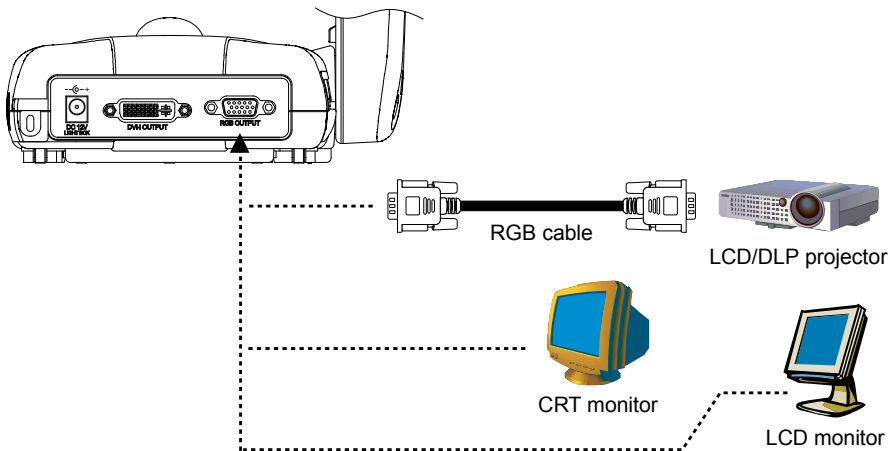

Connect to a Monitor or LCD/DLP Projector with DVI-I interface

Locate the DVI-I input port of the display device and connect it to DVI-I OUTPUT port of AVerVision355AF.



Make sure the TV/RGB switch is set to RGB.

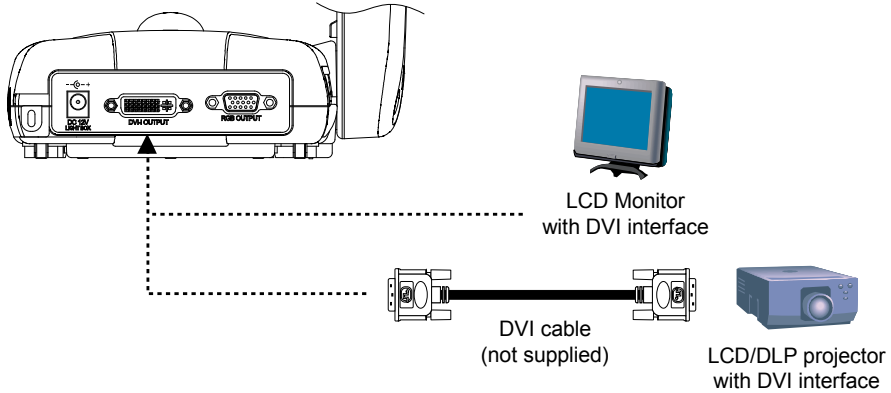

Connect to a TV

Locate the VIDEO or SCART RGB (if applicable) input port of the TV or Video equipment (i.e., VCR) to record your presentation and connect it to RCA jack of RS-232/CVBS cable.

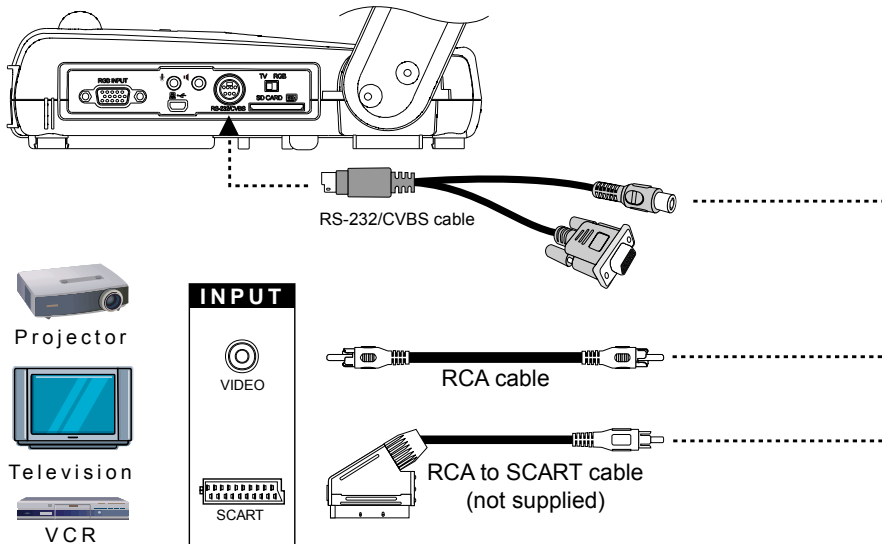

Connecting the Power

Connect the power adapter to a standard 100V~240V AC power outlet. The unit automatically turns on once the power is connected.

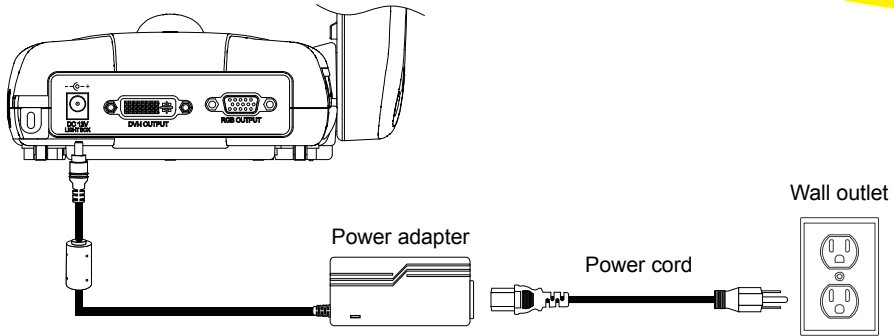

Connect to a Computer

Locate the RGB (VGA) output port of the computer or laptop and connect it to RGB INPUT port of AVerVision355AF. The video signal from the RGB INPUT port is streamed to RGB and DVI-I OUTPUT port.



- To display computer image, press Camera/PC button on the control panel or remote control to switch AVerVision355AF to computer mode.
- For laptop to output display image, use the keyboard command (FN+F5) to switch between the display modes. For different command, please refer to your laptop manual.

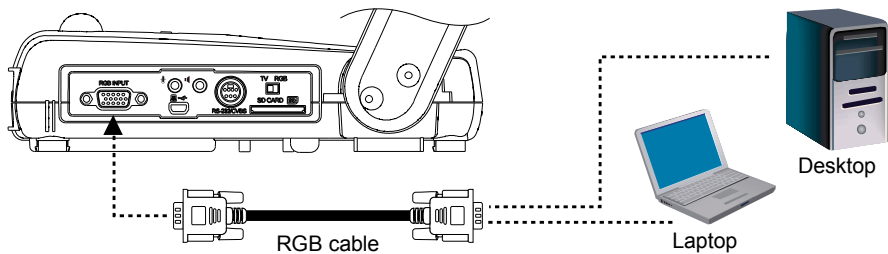

Connect to a Computer via USB

Locate the USB port of the computer or laptop and connect it to **USB port** of AVerVision355AF. This enables you to use AVerVision355AF as a USB Camera or to transfer the captured pictures/videos from the memory and to computer. Also see “Transfer File from AVerVision355AF to PC”.



Make sure the USB Flash Drive switch (see fig. 1.2 #1) is set to the left.

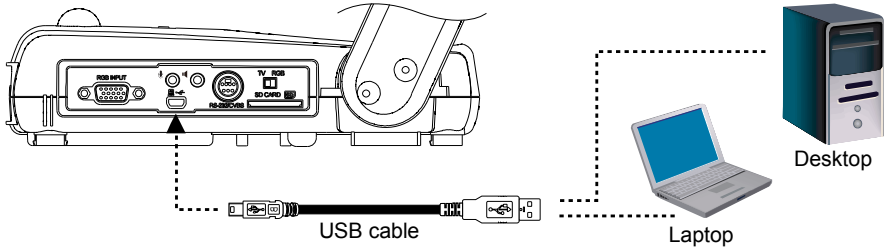

Connect an External Microphone

Plug a 3.5mm mono microphone to  port. The built-in microphone on the control panel will be disabled when an external microphone is connected. The recorded audio will be in monophonic sound.

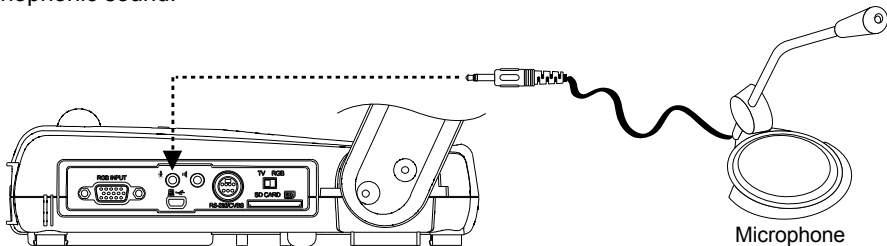

Connect an Amplified Speaker

Plug a 3.5mm plug amplified speaker to  port. Only the audio from the video playback is supported.



We recommend connecting an amplified speaker to the Audio output port. Take caution when using earphones. Adjust the volume down on the remote to prevent hearing damage due to loudness.

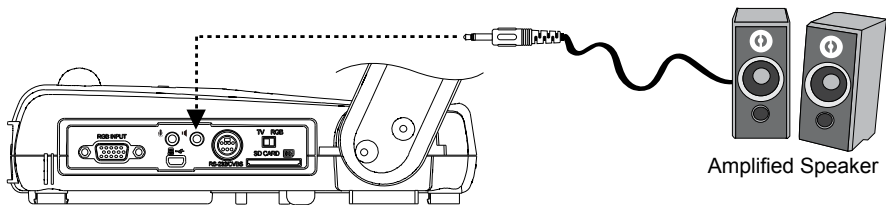

Connect to a Microscope

Connect the AVerVision 355AF to a microscope enables you to examine microscopic objects on a big screen.

1. Change the image display mode to Microscope. Press **MENU** > select **MODE** > select **MICROSCOPE** and press **ENTER**.
2. Adjust the microscope and focus first. Then select the appropriate adapter size for the microscope eyepiece.
3. Remove the microscope eyepiece from the microscope and connect it with the microscope adapter. Fasten the 3 bolts until the adapter secures the eyepiece.
4. Attach the microscope adapter to the AVerVision camera head.



- Make sure to connect the longer hook to the front latch hole of the camera head.
- For the eyepiece, we suggest using 15.5mm eye relief or higher.

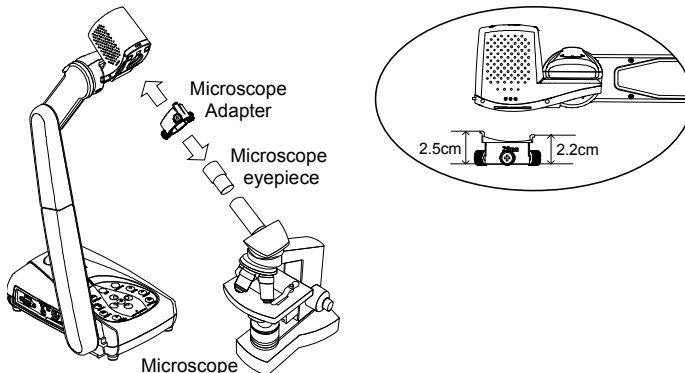

Setting Up AVerVision355AF

This section provides useful tips on how to adjust the AVerVision355AF to meet your needs.

Camera Head

The camera head can turn freely at 90° to the left and right and up and down.

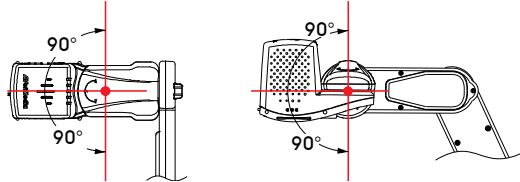

If the camera head is in upright position, you can also press ROTATE on the remote control twice to rotate the image in 180°.

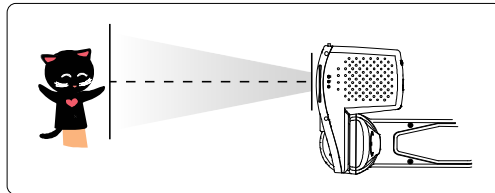

Mechanical Arm

The mechanical arm design can extend for a full A4 paper viewing.

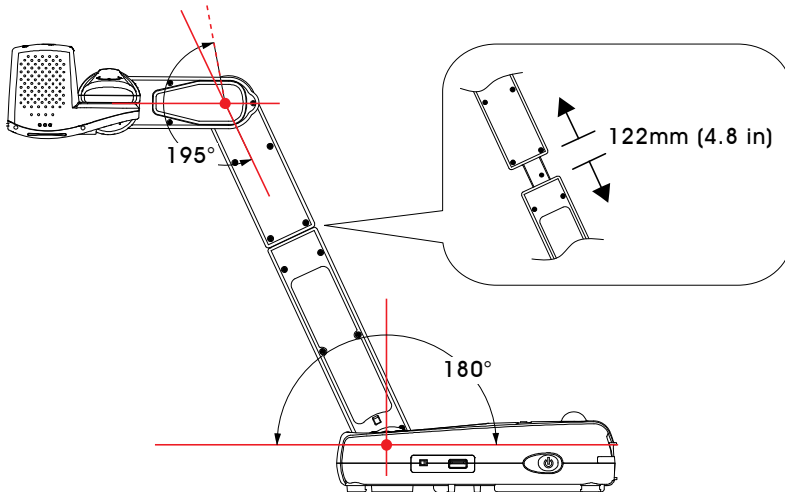

LED Light Switch

AVerVision355AF has patented four (4) laser positioning pointers feature that define the viewing area. This allows user quickly center the object underneath the camera. The three (3) various light and laser positioning pointers settings are indicated in the illustration below.

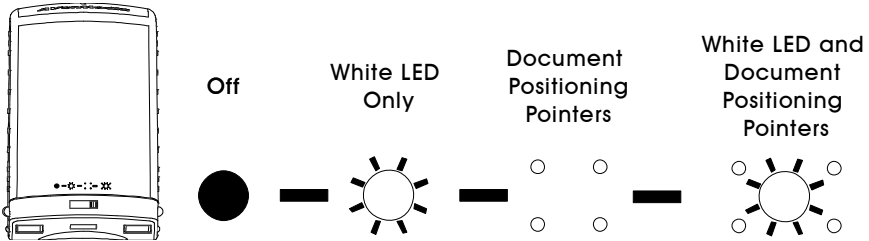

Infrared Sensor

Aim the remote control at the infrared sensor to operate the unit.

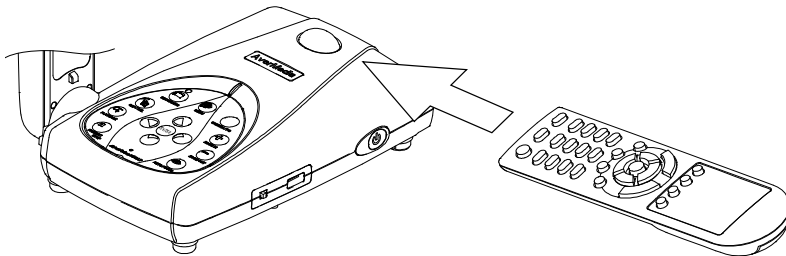

Anti-glare Sheet

The anti-glare sheet is a special coated film that helps eliminate any glare that maybe encountered while displaying very shiny objects or glossy surfaces such as magazines and pictures. To use, simply place the anti-glare sheet on top of the shiny document to reduce reflected light.

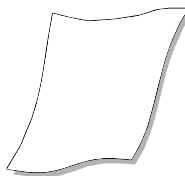

External Memory Storage

AVerVision355AF supports both SD memory card and USB flash drive for more image capture and audio & video recordings. AVerVision355AF can detect when there is an external storage media and automatically switch to the last detected storage. If no external storage is connected, all captured still images will be saved in the built-in memory.

Insert an SD Card

Insert the card with the contact facing down until it reaches the end. To remove the card, push to eject and pull the card out. The supported SD card capacity is from 1GB to 32GB.



SD Card

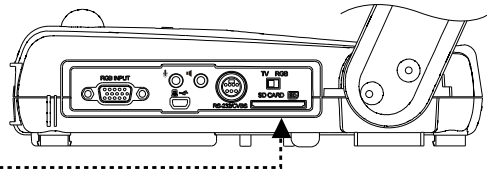

Insert a USB Flash Drive

Make sure to set the USB Flash Drive switch (see fig. 1.2 #1) to the right before inserting a USB flash drive. AVerVision355AF can support USB flash drive from 2GB to 64GB.



USB Flash Drive

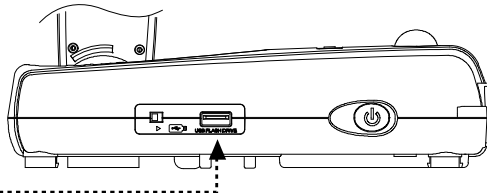

OSD MENU

There are 5 tabs on the OSD menu: BASIC, ADVANCED, PRESENTATION, SETTING and SYSTEM. In Playback mode, you can access PLAYBACK OSD menu to enable the Slide Show feature and modify Slide Show interval and transition setting if desire.



For TV output, the RESOLUTION will be disabled in SETTING menu list.



BASIC



ADVANCED

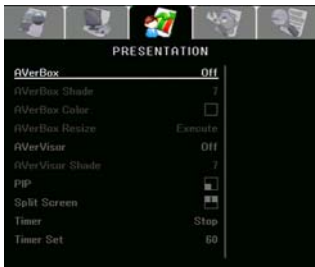

PRESENTATION



SETTING

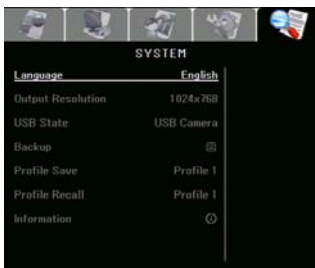

SYSTEM



PLAYBACK

Select Menu and Settings

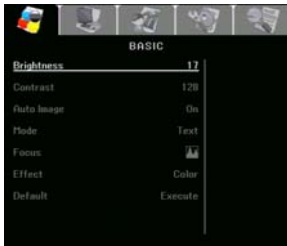

1. Press MENU button on the remote or control panel.
2. Press ► and ◀ to toggle between tabs
3. Press ▼ and ▲ to select a menu option.
4. Press ENTER to make a selection and display the setting selection on the right.
5. Use ► and ◀ to adjust the setting or ▼ and ▲ to make a selection.
6. Press ENTER to make the new setting take effect.
7. Press MENU to close the OSD menu.

Basic

Menu Screen

Function



Brightness

Adjust brightness level manually between 0 and 63.



Contrast

Adjust the contrast level manually between 0 and 255 under bright and dark environments.

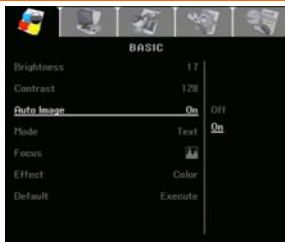

Auto Image

Automatically adjust the white balance and exposure setting and correct the color and exposure compensation.

Menu Screen



Function

MODE

Select various image display settings.

Text - adjust the intensity of text

Graphics - adjust the gradient of image.

High Frame - increase frame rate. Sufficient lighting is required when using this mode.

Microscope - automatically adjust optical zoom for microscopic viewing.

Macro - set to view when object is only 5 – 20 cm away from the camera.

Infinite - set to view when subject is at least 55cm away from the camera.



Focus

Manually adjust the focus.



Effect

Convert the image into positive (true color), monochrome (black and white) or negative.



Default

Restore all the settings into original factory default setting.

Advanced

Menu Screen

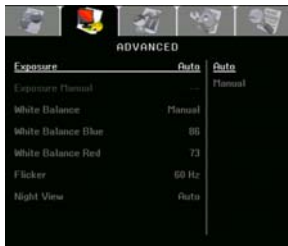

Function

Exposure

Select the exposure setting.

AUTO - automatically adjust the camera exposure and amount of light required.

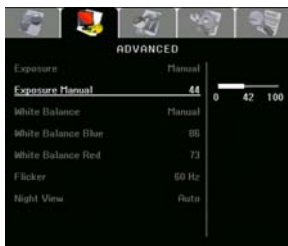

MANUAL - manually adjust the exposure level. The exposure can be adjusted up to 100.



White Balance

Select the White Balance setting for various light conditions or color temperature.

AUTO - automatically adjust the white balance.

MANUAL - manually adjust the red and blue color level. The color level can be adjusted up to 255.

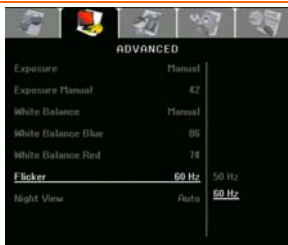
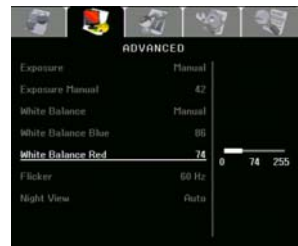
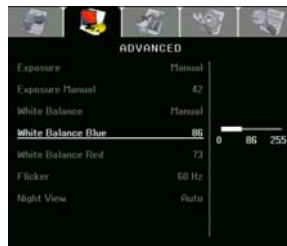

Flicker

Select between 50Hz or 60Hz. Some display devices cannot handle high refresh rates. The image will flicker a couple of times as the output is switched to another refresh rate.

Menu Screen

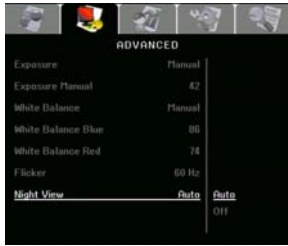

Function

Night View

Select to turn Night View **OFF** or **AUTO**.

When presenting in a low-light condition, Night View enables brighter images by automatically adjusting the exposure and the frame rate will be reduced.

Presentation

Menu Screen



Function

AVerBox On/Off

AVerBox overlays a frame on the presentation screen. You can move the AVerBox around the presentation screen using the ▲, ▼, ◀, & ▶ buttons.

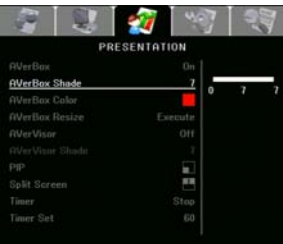
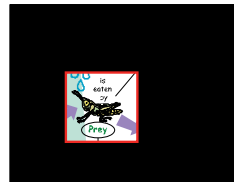

AVerBox Shade

Change the opacity level of the area outside the box. The shaded area completely turns black when it is set to level 7.

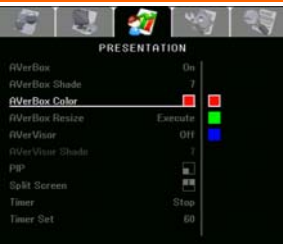

AVerBox Color

Select AVerBox frame color.

Menu Screen

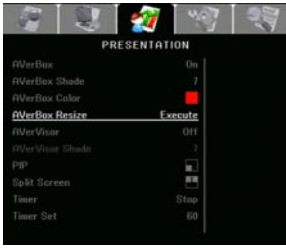

Function

AVerBox Resize

Change AVerBox frame size. The frame blinks when it is in resizable mode. Use the ▲, ▼, ◀, & ▶ buttons to adjust the frame size and press ENTER to set the desired size.

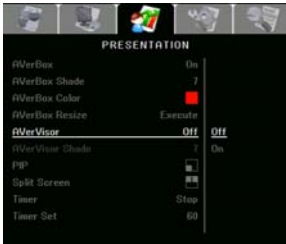

AVerVisor

AVerVisor covers the presentation screen. The upper part of the presentation screen is slightly exposed. Use the ▲, ▼, ◀, & ▶ buttons to reveal more of the covered area.

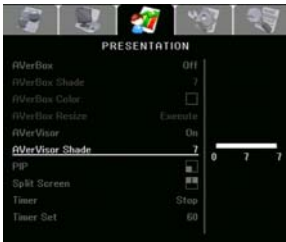

AVerVisor Shade

Change the opacity level of the covered area. The shaded area completely turns black when it is set to level 7.

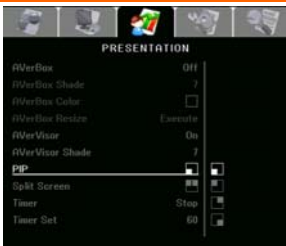

PIP

Select the thumbnail playback screen location and show the thumbnail playback screen at the corner of the screen to recall the captured image from the memory in Camera mode.

- Lower Left
- Upper Left
- Upper Right
- Lower Right

Menu Screen

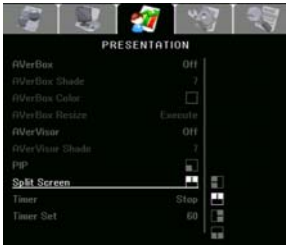

Function

Split Screen

Divide the screen into two parts. Half of the screen displays the 8-thumbnail images and the other half display the image from the AVerVision355AF camera. Select the display location of the 8- thumbnail playback images.

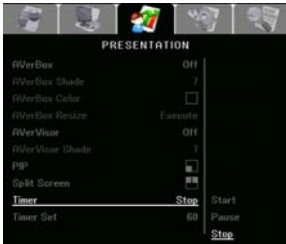

Timer

Start/Pause/Stop the timer. The timer automatically counts up after the count down reaches zero to show the elapsed time. Even when you switch between Playback, PC or Camera modes, the timer will continue.

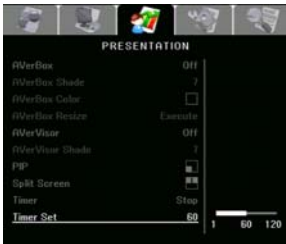

Timer Set

Set the timer value. The timer can be set up to 120 minutes (2 hours).

Setting

Menu Screen



Function

Capture Resolution

Select the capture size. In Normal setting, the capture size depends on the output resolution.

Mode	Output Resolution	Captured Size
Normal	1024 X 768	1024 X 768
	1280 X 720; 1920 X 1080	1280 X 720
	1280 X 960; 1600 X 1200	1280 X 960
5M	-	2592 X 1944

Menu Screen

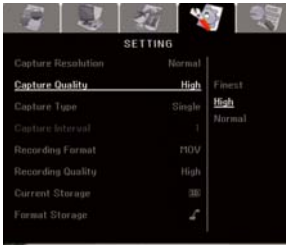

Function

Capture Quality

Select the capture compression setting.



Capture Type

Select the capture type.

Single - capture one picture only.

Continuous - capture successive pictures.

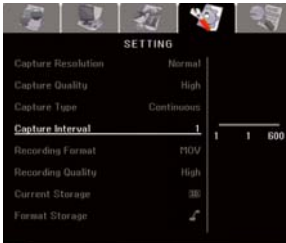

Capture Interval

Set the interval before capturing the next picture. The length can be set up to 600 sec (10 min).



Recording Format

Select the video recording format between MOV and AVI.

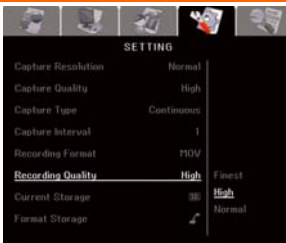

Recording Quality

Select the video recording compression setting.

Menu Screen



Function

Current Storage

Change the storage location. Audio & video recording can only be saved in SD memory card or USB flash drive.



Built-in Memory



SD Memory Card



USB Flash Drive



Format Storage

Format to delete all the data in the selected memory. A Warning Message will appear. Select ✓ to continue and ✗ to stop formatting the storage.

System

Menu Screen



Function

Language

Change and select different language.



Output Resolution

Set the resolution to display the image on screen. This selection will be disabled in TV output mode.

Device	RGB OUTPUT	DVI OUTPUT
RGB Monitor	1024X768	1024X768
	1280X720	1280X720
	1280X960	1280X960
	1600X1200	1600X1200
	1920X1080	1920X1080
LCD TV	-	HD 720P 50HZ
	-	HD 720P 60HZ
	-	HD 1080P 50HZ
	-	HD 1080P 60HZ

Menu Screen

Function



USB State

Select the status of the AVerVision355AF when it is connected to the computer via USB. Make sure the USB Flash Drive switch is set to the left.

USB Camera - can be used as a computer webcam or with our bundled software to record video and capture still image.

Mass Storage - transfer the captured pictures/videos from the memory to computer hard disk.



Backup

Copy the image from the built-in memory to SD or USB flash drive.

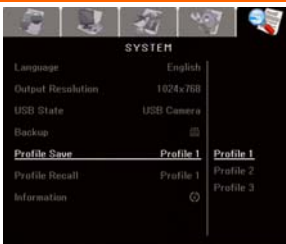

Profile Save

Save current setting in the selected profile number. Only effect, mode, brightness and contrast settings can be saved.

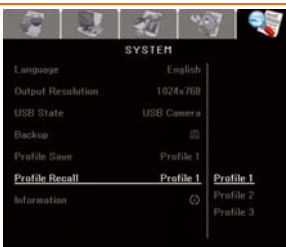

Profile Recall

Restore the setting back to the selected profile number.

Menu Screen



Function

Information

Display product code

Playback

Menu Screen

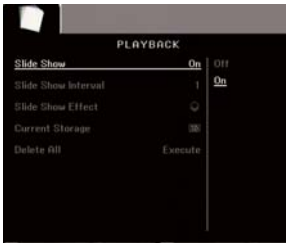

Function

Slide Show

Display all captured still pictures in an automated slide show. The video file will be skipped.



Slide Show Interval

Set the interval before displaying the next picture. The length can be set up to 100 sec.



Slide Show Effect

Select the slide show transition effect.



No effect



Blinds



Split Horizontal In



Split Vertical Out



Checker Down



Use All Effects

Menu Screen



Function

Current Storage

Select the source of the images.



Delete All

Permanently delete all the data in selected memory source. A Warning Message will appear. Select ✓ to continue and ✗ to stop formatting the storage.

Transfer Captured Images/Videos to a computer

This enables you to transfer the captured image from the built-in memory or SD to a computer.



The instruction below **MUST** be read and followed **BEFORE** connecting the USB cable.

1. Make sure to set the USB Flash Drive switch (see fig. 1.2 #1) to the right for the computer to detect AVerVision355AF.
2. **MUST** set the USB STATE as MASS STORAGE before connecting the USB cable.



3. When “Mass Storage Start...” appears at the lower right corner of the presentation screen, you may now connect the USB cable.
4. Upon connecting the USB cable, the system automatically detects the new removable disk. You can now transfer the captured image(s) from the AVERVISION355AF built-in memory to the computer hard disk.

Technical Specifications

Image

Sensor	1/2.5" Progressive Scan CMOS
Pixel Count	5 megapixels
Frame Rate	24 fps (max.)
White Balance	Auto / Manual
Exposure	Auto / Manual
Image mode	Text / Graphics / High Frame / Microscope / Macro / Infinite
Effect	Color / B/W / Negative / Mirror / Rotate / Freeze
RGB output	HD 1080p 60Hz (Reduce blanking); HD 720p 60Hz; UXGA 60 Hz; XGA 60 Hz; 1280 x 960
DVI-I output	HD 1080p 60Hz; HD 720p 60Hz; UXGA 60 Hz; XGA 60 Hz; 1280 x 960; 1080P 50HZ; 1080P 60HZ; 720P 50HZ; 720P 60HZ
Image Capture	240 Frames(XGA) ; 80 Frames(5M Pixel)

Optics

Lens	F3.2 (Wide); F6.8 (Tele)
Focusing	Auto / Manual
Shooting Area	A4 Landscape/ Portrait 400mm x 300mm (47cm camera height)
Zooming	10X AVEROPTICAL™ (5X Optical+2X AVERZOOM™) 8X Digital Zoom

Power

Power Source	DC 12V, 100-240V, 50-60Hz
Consumption	18 Watts (lamp off); 20 Watts (lamp on)

Lighting

Lamp Type	LED light with laser pointer
-----------	------------------------------

Input/Output

RGB Input	15-Pins D-sub (VGA)
RGB Output	15-Pins D-sub (VGA)
DVI-I Output	DVI-I Type
CVBS/RS-232	Mini-DIN Jack (use CVBS/RS-232 Adapter cable)
Composite Video	RCA Jack
USB	USB2.0
DC 12V Input	Power Jack
MIC	Phone Jack
Speaker	Phone Jack

Dimension

Operating	471mm x 174mm x 543mm (+/-2mm include rubber foot)
Folded	367mm x 174mm x 63mm (+/-2mm include rubber foot)
Weight	2.1 kg (about 4.629 lbs)

External Storage

Secure Digital (SD)	1 GB ~ 32GB (FAT 32, 16, 12)
USB Flash Drive	2GB ~ 64GB (FAT 32, 16, 12)

RS-232 Diagram Connection

AVerVision355AF can be controlled using a computer or any centralized control panel through RS-232 connection.

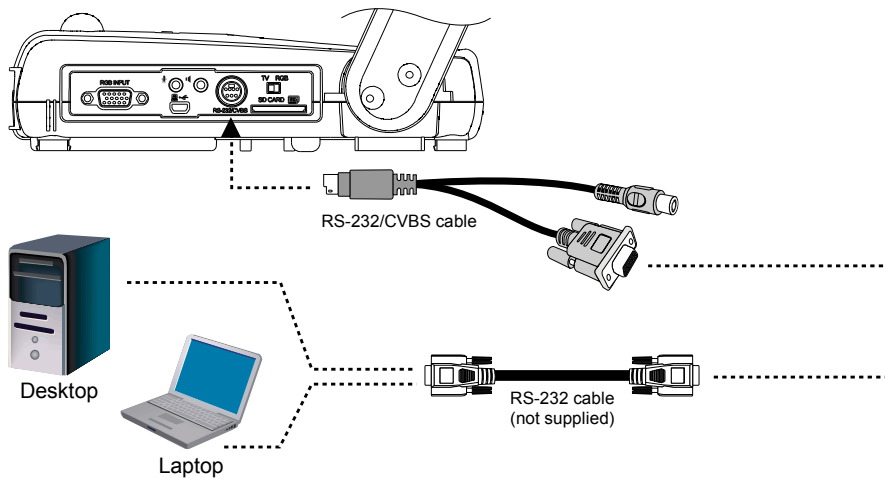

RS-232 Cable Specifications

Make sure the RS-232 cable matches the cable specification design.

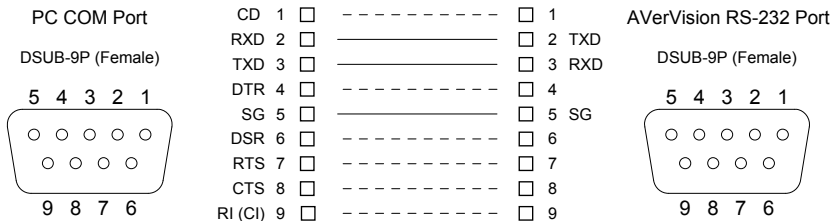

RS-232 Transmission Specifications

- Start bit : 1 bit
- Data bit : 8 bit
- Stop bit : 1 bit
- Parity bit : None
- X parameter : None
- Baud rate(Communication speed) : 9600bps

RS-232 Communication Format

Start Code(1 Byte) : 0xFF
 Type Code(1 Byte) : 0x70
 DataLength Code(1 Byte) : 0x01
 Data Code(1 Byte) : See the Command Table for reference.
 CheckSum Code(1 Byte) : See the Command Table for reference.
 Format : Start + Type + DataLength + Data + CheckSum
 Example : 0xFF + 0x70 + 0x01+ 0x1 + 0x70 (Command Power)

RS-232 Command Table

Send Format : 0x52 + 0x05 + 0x01 + Command + 0x53 + CheckSum

Receive Format : 0x51 + 0x00 + 0x01 + 0x05 + 0x51 + 0x55

Function	Command Code	CheckSum Code	RS-232 Code
POWER	00	57	52,05,01,00,53,57
PC/ CAMERA	4A	1D	52,05,01,4A,53,1D
PLAYBACK	0B	5C	52,05,01,0B,53,5C
TIMER	01	56	52,05,01,01,53,56
AVERBOX	02	55	52,05,01,02,53,55
AVERVISOR	03	54	52,05,01,03,53,54
MIRROR	04	53	52,05,01,04,53,53
SPLIT SCREEN	05	52	52,05,01,05,53,52
PIP	06	51	52,05,01,06,53,51
ROTATE	07	50	52,05,01,07,53,50
EFFECT	08	5F	52,05,01,08,53,5F
SLITE SHOW	09	5E	52,05,01,09,53,5E
FREEZE/STOP	0C	5B	52,05,01,0C,53,5B
RECORDING	0A	5D	52,05,01,0A,53,5D
CAPTURE	0D	5A	52,05,01,0D,53,5A
AUTO FOCUS	0F	58	52,05,01,0F,53,58
AUTO IMAGE	10	47	52,05,01,10,53,47
MENU	0E	59	52,05,01,0E,53,59

Function	Command Code	CheckSum Code	RS-232 Code
DEL	11	46	52,05,01,11,53,46
ARROW - UPPER	12	45	52,05,01,12,53,45
ARROW - LEFT	13	44	52,05,01,13,53,44
ARROW - ENTER	14	43	52,05,01,14,53,43
ARROW - RIGHT	15	42	52,05,01,15,53,42
ZOOM +	17	40	52,05,01,17,53,40
EXPOSURE +	18	4F	52,05,01,18,53,4F
ARROW - DOWN	16	41	52,05,01,16,53,41
ZOOM -	4B	1C	52,05,01,4B,53,1C
EXPOSURE -	4C	1B	52,05,01,4C,53,1B
ZOOM RESET	19	4E	52,05,01,19,53,4E
NER	1A	4D	52,05,01,1A,53,4D
FAR	1B	4C	52,05,01,1B,53,4C
DEFAULT	1C	4B	52,05,01,1C,53,4B
PC PASSTHROUGH	4D	1A	52,05,01,4D,53,1A
CAMERA	4E	19	52,05,01,4E,53,19

RS-232 Function Table

Send Format : 0x52 + 0x0B + 0x03 + Data[0] + Data[1] + Data[2] + 0x53 + CheckSum

Receive Format : 0x51 + 0x00 + 0x01 + 0x0B + 0x51 + 0x5B

Function	Data[0]	Data[1]	Data[2]	CheckSum Code	RS-232 Code
POWER OFF	0x01	0x00	0x00	0x5A	52,0B,03,01,00,00,53,5A
POWER ON	0x01	0x01	0x00	0x5B	52,0B,03,01,01,00,53,5B
IMAGE CAPTURE TYPE: SINGLE	0x02	0x00	0x00	0x59	52,0B,03,02,00,00,53,59
IMAGE CAPTURE TYPE: CONTINUOUS	0x02	0x01	0x00	0x58	52,0B,03,02,01,00,53,58
IMAGE CAPTURE CONTINUOUS INTERVAL INCREASE	0x03	0x00	0x00	0x58	52,0B,03,03,00,00,53,58
IMAGE CAPTURE CONTINUOUS INTERVAL DECREASE	0x04	0x00	0x00	0x5F	52,0B,03,04,00,00,53,5F

Function	Data[0]	Data[1]	Data[2]	Checksum Code	RS-232 Code
IMAGE CAPTURE RESOLUTION: NORMAL	0x05	0x00	0x00	0x5E	52,0B,03,05,00,00,53,5E
IMAGE CAPTURE RESOLUTION: 5M	0x05	0x01	0x00	0x5F	52,0B,03,05,01,00,53,5F
TIMER START	0x06	0x00	0x00	0x5D	52,0B,03,06,00,00,53,5D
TIMER PAUSE	0x07	0x00	0x00	0x5C	52,0B,03,07,00,00,53,5C
TIMER STOP	0x08	0x00	0x00	0x53	52,0B,03,08,00,00,53,53
TIMER SET TIME	0x09	Value[1~120]	0x00	*1	*1
NIGHTVIEW OFF	0x0A	0x00	0x00	0x51	52,0B,03,0A,00,00,53,51
NIGHTVIEW ON	0x0A	0x01	0x00	0x50	52,0B,03,0A,01,00,53,50
PREVIEW MODE: TEXT	0x0B	0x00	0x00	0x50	52,0B,03,0B,00,00,53,50
PREVIEW MODE: GRAPHIC	0x0B	0x01	0x00	0x51	52,0B,03,0B,01,00,53,51
PREVIEW MODE: HIGH FRAME	0x0B	0x02	0x00	0x52	52,0B,03,0B,02,00,53,52
PREVIEW MODE: MICROSCOPE	0x0B	0x03	0x00	0x53	52,0B,03,0B,03,00,53,53
PREVIEW MODE: MACRO	0x0B	0x04	0x00	0x54	52,0B,03,0B,04,00,53,54
PREVIEW MODE: INFINITE	0x0B	0x05	0x00	0x55	52,0B,03,0B,05,00,53,55
PLAYBACK FULL SCREEN	0x0C	0x00	0x00	0x57	52,0B,03,0C,00,00,53,57
MIRROR OFF	0x0E	0x00	0x00	0x55	52,0B,03,0E,00,00,53,55
MIRROR ON	0x0E	0x01	0x00	0x54	52,0B,03,0E,01,00,53,54
ROTATE 0	0x0F	0x00	0x00	0x54	52,0B,03,0F,00,00,53,54
ROTATE 90	0x0F	0x01	0x00	0x55	52,0B,03,0F,01,00,53,55
ROTATE 180	0x0F	0x02	0x00	0x56	52,0B,03,0F,02,00,53,56
ROTATE 270	0x0F	0x03	0x00	0x57	52,0B,03,0F,03,00,53,57

Function	Data[0]	Data[1]	Data[2]	Checksum Code	RS-232 Code
EFFECT: COLOR	0x10	0x00	0x00	0x4B	52,0B,03,10,00,00,53,4B
EFFECT: B/W	0x10	0x01	0x00	0x4A	52,0B,03,10,01,00,53,4A
EFFECT: NEGATIVE	0x10	0x02	0x00	0x49	52,0B,03,10,02,00,53,49
CONTRAST	0x11	Value[0~63]	0x00	*1	*1
BRIGHTNESS	0x12	Value[0~255]	0x00	*1	*1
AUTO IMAGE OFF	0x13	0x00	0x00	0x48	52,0B,03,13,00,00,53,48
AUTO IMAGE ON	0x13	0x01	0x00	0x49	52,0B,03,13,01,00,53,49
EXPOSURE: AUTO	0x14	0x00	0x00	0x4F	52,0B,03,14,00,00,53,4F
EXPOSURE: MANUAL	0x14	0x01	0x00	0x4E	52,0B,03,14,01,00,53,4E
EXPOSURE MANUAL INCREASE	0x15	0x00	0x00	0x4E	52,0B,03,15,00,00,53,4E
EXPOSURE MANUAL DECREASE	0x16	0x00	0x00	0x4D	52,0B,03,16,00,00,53,4D
WHITE BALANCE: AUTO	0x17	0x00	0x00	0x4C	52,0B,03,17,00,00,53,4C
WHITE BALANCE: MANUAL	0x17	0x01	0x00	0x4D	52,0B,03,17,01,00,53,4D
WHITE BALANCE BLUE INCREASE	0x18	0x00	0x00	0x43	52,0B,03,18,00,00,53,43
WHITE BALANCE BLUE DECREASE	0x19	0x00	0x00	0x42	52,0B,03,19,00,00,53,42
WHITE BALANCE RED INCREASE	0x1A	0x00	0x00	0x41	52,0B,03,1A,00,00,53,41
WHITE BALANCE RED DECREASE	0x1B	0x00	0x00	0x40	52,0B,03,1B,00,00,53,40
FLICKER: 50Hz	0x1C	0x00	0x00	0x47	52,0B,03,1C,00,00,53,47
FLICKER: 60Hz	0x1C	0x01	0x00	0x46	52,0B,03,1C,01,00,53,46
FLICKER: AUTO	0x1C	0x02	0x00	0x45	52,0B,03,1C,02,00,53,45

Function	Data[0]	Data[1]	Data[2]	Checksum Code	RS-232 Code
AVERBOX: OFF	0x1D	0x00	0x00	0x46	52,0B,03,1D,00,00,53,46
AVERBOX: ON	0x1D	0x01	0x00	0x47	52,0B,03,1D,01,00,53,47
AVERBOX SHADE Level 0	0x1E	0x00	0x00	0x45	52,0B,03,1E,00,00,53,45
AVERBOX SHADE Level 4	0x1E	0x01	0x00	0x44	52,0B,03,1E,01,00,53,44
AVERBOX SHADE Level 7	0x1E	0x02	0x00	0x47	52,0B,03,1E,02,00,53,47
AVERBOX COLOR: RED	0x1F	0xF9	0x00	0xBD	52,0B,03,1F,F9,00,53,BD
AVERBOX COLOR: GREEN	0x1F	0xFA	0x00	0xBE	52,0B,03,1F,FA,00,53,BE
AVERBOX COLOR: BLUE	0x1F	0xFC	0x00	0xB8	52,0B,03,1F,FC,00,53,B8
AVERBOX RESIZE	0x20	0x00	0x00	0x7B	52,0B,03,20,00,00,53,7B
AVERVISOR: OFF	0x21	0x00	0x00	0x7A	52,0B,03,21,00,00,53,7A
AVERVISOR: ON	0x21	0x01	0x00	0x7B	52,0B,03,21,01,00,53,7B
AVERVISOR SHADE Level 0	0x22	0x00	0x00	0x80	52,0B,03,22,00,00,53,79
AVERVISOR SHADE Level 4	0x22	0x01	0x00	0x83	52,0B,03,22,01,00,53,78
AVERVISOR SHADE Level 7	0x22	0x02	0x00	0x85	52,0B,03,22,02,00,53,7B
PIP: OFF	0x23	0x00	0x00	0x78	52,0B,03,23,00,00,53,78
PIP: ON	0x23	0x01	0x00	0x79	52,0B,03,23,01,00,53,79
PIP POSITION: BOTTOM LEFT	0x24	0x00	0x00	0x7F	52,0B,03,24,00,00,53,7F
PIP POSITION: TOP LEFT	0x24	0x01	0x00	0x7E	52,0B,03,24,01,00,53,7E
PIP POSITION: TOP RIGHT	0x24	0x02	0x00	0x7D	52,0B,03,24,02,00,53,7D
PIP POSITION: BOTTOM RIGHT	0x24	0x03	0x00	0x7C	52,0B,03,24,03,00,53,7C
SPLITSCREEN: OFF	0x25	0x00	0x00	0x7E	52,0B,03,25,00,00,53,7E
SPLITSCREEN: ON	0x25	0x01	0x00	0x7F	52,0B,03,25,01,00,53,7F
SPLITSCREEN DIR: UPPER SCREEN	0x26	0x01	0x00	0x7C	52,0B,03,26,01,00,53,7C

Function	Data[0]	Data[1]	Data[2]	CheckSum Code	RS-232 Code
SPLITSCREEN DIR: LOWER SCREEN	0x26	0x02	0x00	0x7F	52,0B,03,26,02,00,53,7F
SPLITSCREEN DIR: LEFT SCREEN	0x26	0x03	0x00	0x7E	52,0B,03,26,03,00,53,7E
SPLITSCREEN DIR: RIGHT SCREEN	0x26	0x04	0x00	0x79	52,0B,03,26,04,00,53,79
RECORD: OFF	0x27	0x00	0x00	0x7C	52,0B,03,27,00,00,53,7C
RECORD: ON	0x27	0x01	0x00	0x7D	52,0B,03,27,01,00,53,7D
RECORD FORMAT: MOV	0x28	0x00	0x00	0x73	52,0B,03,28,00,00,53,73
RECORD FORMAT: AVI	0x28	0x01	0x00	0x72	52,0B,03,28,01,00,53,72
MOVIE FAST REWIND	0x29	0x00	0x00	0x72	52,0B,03,29,00,00,53,72
MOVIE FAST FORWARD	0x2A	0x00	0x00	0x71	52,0B,03,2A,00,00,53,71
MOVIE VOL INC	0x2B	0x00	0x00	0x70	52,0B,03,2B,00,00,53,70
MOVIE VOL DEC	0x2C	0x00	0x00	0x77	52,0B,03,2C,00,00,53,77
RECORD QUALITY: STANDARD	0x2D	0x00	0x00	0x76	52,0B,03,2D,00,00,53,76
RECORD QUALITY: FINE	0x2D	0x01	0x00	0x77	52,0B,03,2D,01,00,53,77
RECORD QUALITY: FINEST	0x2D	0x02	0x00	0x74	52,0B,03,2D,02,00,53,74
STORAGE: EMBEDDED	0x2E	0x00	0x00	0x75	52,0B,03,2E,00,00,53,75
STORAGE: SD CARD	0x2E	0x01	0x00	0x74	52,0B,03,2E,01,00,53,74
STORAGE: THUMB DRIVE	0x2E	0x02	0x00	0x77	52,0B,03,2E,02,00,53,77
FORMAT: EMBEDDED	0x2F	0x00	0x00	0x74	52,0B,03,2F,00,00,53,74
FORMAT: SD CARD	0x2F	0x01	0x00	0x75	52,0B,03,2F,01,00,53,75
OUTPUT RESOLUTION: 1024x768	0x30	0x00	0x00	0x6B	52,0B,03,30,00,00,53,6B
OUTPUT RESOLUTION: 1280x720	0x30	0x01	0x00	0x6A	52,0B,03,30,01,00,53,6A

Function	Data[0]	Data[1]	Data[2]	Checksum Code	RS-232 Code
OUTPUT RESOLUTION: 1280x960	0x30	0x02	0x00	0x69	52,0B,03,30,02,00,53,69
OUTPUT RESOLUTION: 1600x1200	0x30	0x03	0x00	0x68	52,0B,03,30,03,00,53,68
OUTPUT RESOLUTION: 1920x1080	0x30	0x04	0x00	0x6F	52,0B,03,30,04,00,53,6F
OUTPUT RESOLUTION: HD720P 50Hz	0x30	0x05	0x00	0x6E	52,0B,03,30,05,00,53,6E
OUTPUT RESOLUTION: HD720P 60Hz	0x30	0x06	0x00	0x6D	52,0B,03,30,06,00,53,6D
OUTPUT RESOLUTION: HD1080P 50Hz	0x30	0x07	0x00	0x6C	52,0B,03,30,07,00,53,6C
OUTPUT RESOLUTION: HD1080P 60Hz	0x30	0x08	0x00	0x63	52,0B,03,30,08,00,53,63
USB CONNECT: USB CAMERA	0x31	0x00	0x00	0x6A	52,0B,03,31,00,00,53,6A
USB CONNECT: MASS STORAGE	0x31	0x01	0x00	0x6B	52,0B,03,31,01,00,53,6B
BACKUP TO SD CARD	0x32	0x00	0x00	0x69	52,0B,03,32,00,00,53,69
BACKUP TO THUMBDRIVE	0x32	0x01	0x00	0x68	52,0B,03,32,01,00,53,68
PROFILE SAVE: PROFILE 1	0x33	0x00	0x00	0x68	52,0B,03,33,00,00,53,68
PROFILE SAVE: PROFILE 2	0x33	0x01	0x00	0x69	52,0B,03,33,01,00,53,69
PROFILE SAVE: PROFILE 3	0x33	0x02	0x00	0x6A	52,0B,03,33,02,00,53,6A
PROFILE RECALL: PROFILE 1	0x34	0x00	0x00	0x6F	52,0B,03,34,00,00,53,6F
PROFILE RECALL: PROFILE 2	0x34	0x01	0x00	0x6E	52,0B,03,34,01,00,53,6E
PROFILE RECALL: PROFILE 3	0x34	0x02	0x00	0x6D	52,0B,03,34,02,00,53,6D

Function	Data[0]	Data[1]	Data[2]	Checksum Code	RS-232 Code
SLIDESHOW: OFF	0x36	0x00	0x00	0x6D	52,0B,03,36,00,00,53,6D
SLIDESHOW: ON	0x36	0x01	0x00	0x6C	52,0B,03,36,01,00,53,6C
SLIDESHOW EFFECT: NO EFFECT	0x37	0x00	0x00	0x6C	52,0B,03,37,00,00,53,6C
SLIDESHOW EFFECT: EFFECT 1	0x37	0x01	0x00	0x6D	52,0B,03,37,01,00,53,6D
SLIDESHOW EFFECT: EFFECT 2	0x37	0x02	0x00	0x6E	52,0B,03,37,02,00,53,6E
SLIDESHOW EFFECT: EFFECT 3	0x37	0x03	0x00	0x6F	52,0B,03,37,03,00,53,6F
SLIDESHOW EFFECT: EFFECT 4	0x37	0x04	0x00	0x68	52,0B,03,37,04,00,53,68
SLIDESHOW EFFECT: RANDOM EFFECT	0x37	0x05	0x00	0x69	52,0B,03,37,05,00,53,69

*1 : CheckSum = 0x0B xor 0x03 xor Data[0] xor Data[1] xor Data[2] xor 0x53

Troubleshooting

This section provides many useful tips on how to solve common problems while using the AVerVision355AF.

There is no picture on the presentation screen.

1. Check all the connectors again as shown in this manual.
2. Check the on/off switch of the display output device.
3. Verify the setting of the display output device.
4. If you are presenting from a notebook or computer through the display output device, check the cable connection from computer RGB (VGA) output to RGB input of AVerVision355AF and make sure AVerVision355AF is in PC Mode.

I have set up the AVerVision355AF and checked all the connections as specified in the manual but I cannot get a picture on the preferred presentation screen.

1. The unit POWER button turns orange in standby mode. Press the POWER button again to turn on and the LED light will turn blue.
2. The default camera display resolution setting is on 1024x768. If your output device does not support this resolution; no image can be projected. Simply press hold the FREEZE and ► button to the change the resolution setting.
3. If your display output device is on TV or any analog device, please switch the TV-RGB dip switch to TV.

The picture on the presentation screen is distorted or the image is blurry.

1. Reset all changed settings, if any, to the original manufacturer default setting. Press **DEFAULT** on the remote or select Default in Basic tab OSD menu.
2. Use the Brightness and Contrast menu functions to reduce the distortion if applicable.

3. If you discover that the image is blurry or out of focus, press the Auto Focus button on the control panel or remote control.

There is no computer signal on presentation screen.

1. Check all the cable connections among the display device, AVerVision355AF and your PC.
2. Connect your PC to the AVerVision355AF first before you power on your computer.
3. For notebook, repeatedly press FN+F5 to toggles between display modes and display the computer image on the presentation screen. For different command, please refer to your laptop manual.

The presentation screen does not show the exact desktop image on my PC or Notebook after I toggle from Camera to PC mode.

1. Return to your PC or Notebook, place the mouse on the desktop and right click, choose "Properties", choose "Setting" tab, click on "2" monitor and check the box "Extend my Windows desktop onto this monitor".
2. Then go back one more time to your PC or Notebook and place the mouse on the desktop and right click again.
3. This time choose "Graphics Options", then "Output To", then "Intel® Dual Display Clone", and then choose "Monitor + Notebook".
4. After you follow these steps, you should be able to see the same desktop image on your PC or Notebook as well as on the presentation screen.

AVerVision355AF can't detect the inserted USB flash drive.

Make sure the USB flash drive switch is set to the right and check if the USB flash drive is properly inserted.

Limited Warranty

For a period of time beginning on the date of purchase of the applicable product and extending as set forth in the **"Warranty Period of AVerMedia Product Purchased"** section of the warranty card, AVerMedia Information, Inc. ("AVerMedia") warrants that the applicable product ("Product") substantially conforms to AVerMedia's documentation for the product and that its manufacture and components are free of defects in material and workmanship under normal use. "You" as used in this agreement means you individually or the business entity on whose behalf you use or install the product, as applicable. This limited warranty extends only to You as the original purchaser. Except for the foregoing, the Product is provided "AS IS." In no event does AVerMedia warrant that You will be able to operate the Product without problems or interruptions, or that the Product is suitable for your purposes. Your exclusive remedy and the entire liability of AVerMedia under this paragraph shall be, at AVerMedia's option, the repair or replacement of the Product with the same or a comparable product. This warranty does not apply to (a) any Product on which the serial number has been defaced, modified, or removed, or (b) cartons, cases, batteries, cabinets, tapes, or accessories used with this product. This warranty does not apply to any Product that has suffered damage, deterioration or malfunction due to (a) accident, abuse, misuse, neglect, fire, water, lightning, or other acts of nature, commercial or industrial use, unauthorized product modification or failure to follow instructions included with the Product, (b) misapplication of service by someone other than the manufacturer's representative, (c) any shipment damages (such claims must be made with the carrier), or (d) any other causes that do not relate to a Product defect. The Warranty Period of any repaired or replaced Product shall be the longer of (a) the original Warranty Period or (b) thirty (30) days from the date of delivery of the repaired or replaced product.

Limitations of Warranty

AVerMedia makes no warranties to any third party. You are responsible for all claims, damages, settlements, expenses, and attorneys' fees with respect to claims made against You as a result of Your use or misuse of the Product. This warranty applies only if the Product is installed, operated, maintained, and used in accordance with AVerMedia specifications. Specifically, the warranties do not extend to any failure caused by (i) accident, unusual physical, electrical, or electromagnetic stress,

neglect or misuse, (ii) fluctuations in electrical power beyond AVerMedia specifications, (iii) use of the Product with any accessories or options not furnished by AVerMedia or its authorized agents, or (iv) installation, alteration, or repair of the Product by anyone other than AVerMedia or its authorized agents.

Disclaimer of Warranty

EXCEPT AS EXPRESSLY PROVIDED OTHERWISE HEREIN AND TO THE MAXIMUM EXTENT PERMITTED BY APPLICABLE LAW, AVERMEDIA DISCLAIMS ALL OTHER WARRANTIES WITH RESPECT TO THE PRODUCT, WHETHER EXPRESS, IMPLIED, STATUTORY OR OTHERWISE, INCLUDING WITHOUT LIMITATION, SATISFACTORY QUALITY, COURSE OF DEALING, TRADE USAGE OR PRACTICE OR THE IMPLIED WARRANTIES OF MERCHANTABILITY, FITNESS FOR A PARTICULAR PURPOSE OR NONINFRINGEMENT OF THIRD PARTY RIGHTS.

Limitation of Liability

IN NO EVENT SHALL AVERMEDIA BE LIABLE FOR INDIRECT, INCIDENTAL, SPECIAL, EXEMPLARY, PUNITIVE, OR CONSEQUENTIAL DAMAGES OF ANY NATURE INCLUDING, BUT NOT LIMITED TO, LOSS OF PROFITS, DATA, REVENUE, PRODUCTION, OR USE, BUSINESS INTERRUPTION, OR PROCUREMENT OF SUBSTITUTE GOODS OR SERVICES ARISING OUT OF OR IN CONNECTION WITH THIS LIMITED WARRANTY, OR THE USE OR PERFORMANCE OF ANY PRODUCT, WHETHER BASED ON CONTRACT OR TORT, INCLUDING NEGLIGENCE, OR ANY OTHER LEGAL THEORY, EVEN IF AVERMEDIA HAS ADVISED OF THE POSSIBILITY OF SUCH DAMAGES. AVERMEDIA'S TOTAL, AGGREGATE LIABILITY FOR DAMAGES OF ANY NATURE, REGARDLESS OF FORM OF ACTION, SHALL IN NO EVENT EXCEED THE AMOUNT PAID BY YOU TO AVERMEDIA FOR THE SPECIFIC PRODUCT UPON WHICH LIABILITY IS BASED.

Governing Law and Your Rights

This warranty gives you specific legal rights; You may also have other rights granted under state law. These rights vary from state to state.



For warranty period, please refer to the warranty card.
